



# Cisco 100Gbps QSFP100 SR1.2 BiDi Pluggable Transceiver

## Expanding Cisco's BiDi portfolio

The Cisco QSFP-100G-SR1.2 BiDi is a parallel Quad Small Form-factor Pluggable (QSFP28) Bi-Direction optical module that supports 100 Gbps bit rates. The module integrates four host electrical data into two optical lanes over a 2-fiber duplex LC optical multi-mode fiber. The QSFP 100G SR1.2 BiDi operates 50Gb PAM4 channels, for a total aggregate bandwidth of 100Gb. PAM4 technology enables 50Gb data rate with signaling at 25Gbaud rates. Reversely, on the receiver side, the module de-multiplexes 2 sets of optical input signal and converts them to 4 channels of electrical data. An optical fiber ribbon cable with an LC connector can be plugged into the QSFP28 module. The QSFP 100G SR1.2 BiDi is compliant to IEEE802.3bm 100GBASE-SR4.

The Cisco QSFP-100G-SR1.2 BiDi transceiver will operate with a Cisco QSFP-100G-SR1.2 BiDi for 100G connectivity. It can also connect to a Cisco 400 Gbps SR4.2 BiDi in a 4 x 100G breakout mode. The Cisco QSFP-100G-SR1.2 BiDi will not interoperate with the Cisco QSFP-40/100-SRBD.



## Benefits

- Lower capital expenditure by reusing of the duplex LC Multimode Fiber (MMF) infrastructure
- Reduce operational expenditure by seamlessly upgrading to 100Gbps rate from 10Gbps SR or 40Gbps BiDi
- Future proof the network by providing connectivity to 400 Gbps rate
- Reduce transmission errors with KP4 Forward Error Correction (FEC) at 100Gbps data rate

Figure 1 below shows all the interoperability options for Cisco's BiDi portfolio:

Figure 1. Cisco BiDi interoperability options

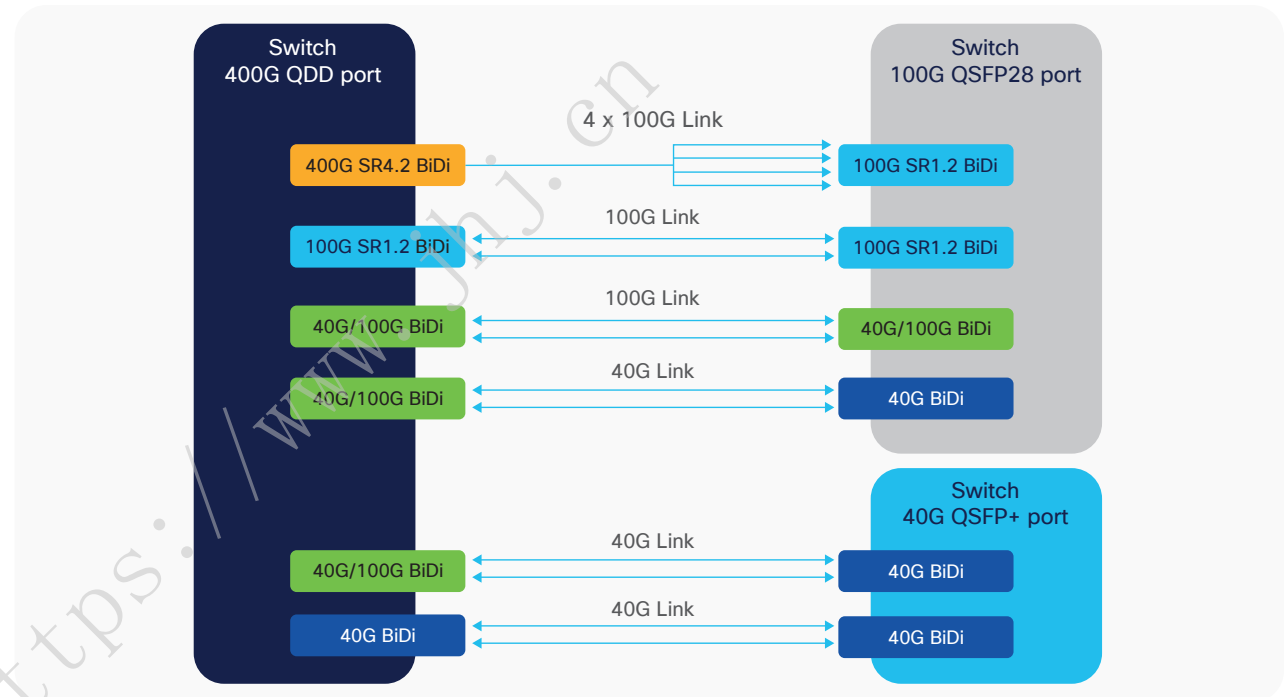

## Upgrade seamlessly from 40 Gb or 10 Gb to 100 Gbps with a path toward 400G

Mission-critical workloads such as artificial intelligence and machine learning are increasing the computation and traffic requirements within the fabric. This is driving a move to denser and higher-speed connectivity both within the leaf and spine and between the leaf/top-of-rack switch to the server.

In Figure 2 below, the, 400Gbps SR4.2 can be deployed in the spine layer, which is the backbone of the network, connecting to the leaf node in a breakout model. An alternative option would be to deploy the QSFP-100G-SR1.2 BiDi in both the spine and leaf nodes, with a path toward upgrading the spine nodes to 400G as bandwidth demand grows.

Figure 2. Leaf spine connectivity using QSFP-100G-SR1.2 optics

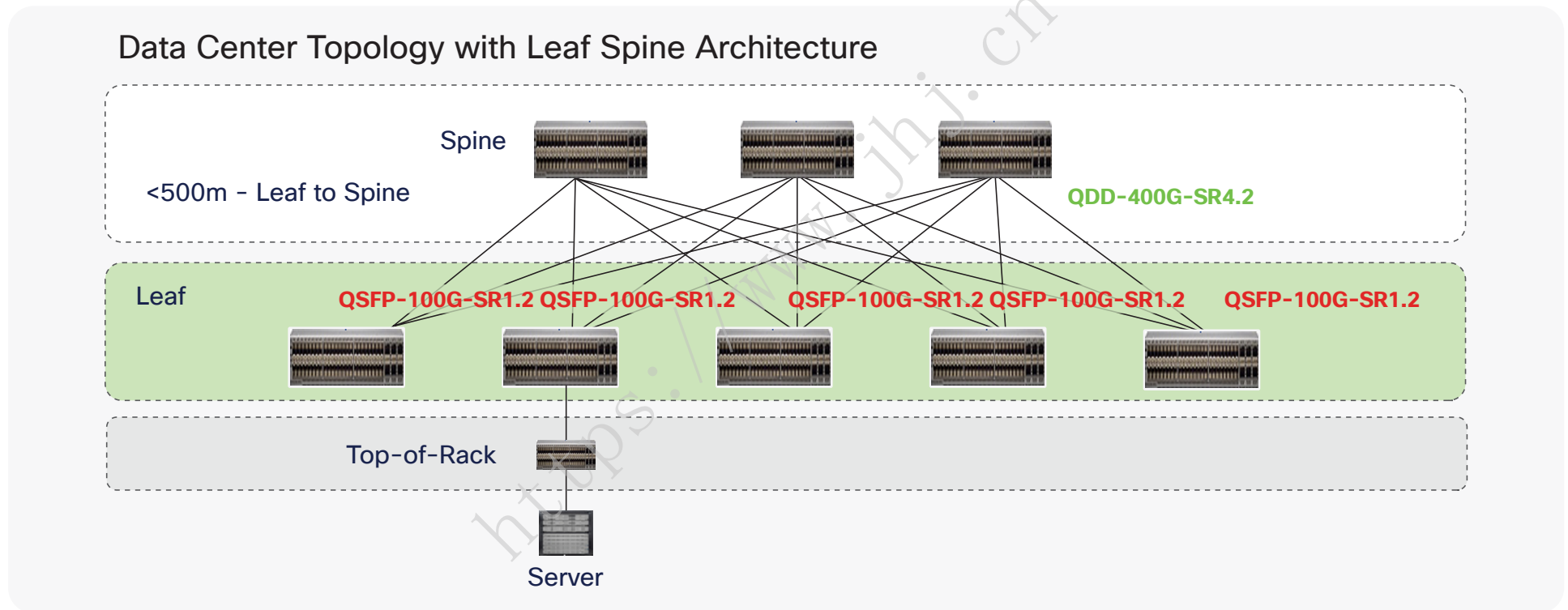

### Learn more

For more information about Cisco transceivers, see: [www.cisco.com/c/en/us/products/interfaces-modules/transceiver-modules/index.html?dtid=ossdc000283](http://www.cisco.com/c/en/us/products/interfaces-modules/transceiver-modules/index.html?dtid=ossdc000283)

For optics-to-optics and optics-to-platform compatibility, see: <https://tmgmatrix.cisco.com/>

For optics product information, see: <https://copi.cisco.com/?tpid=1622>

In Figure 3 below, given the reach and operational flexibility with pluggable transceivers compared to preassembled cable, operators may use the QSFP-100G-SR1.2 BiDi for top-of-rack connectivity to the servers or deploy 400G in the TOR and connect downstream to the server using 1 x QDD-400G-SR4.2 to 4 x QSFP-100G-SR1.2 in a breakout model.

Figure 3. Switch to server connectivity using QSFP-100G-SR1.2 optics

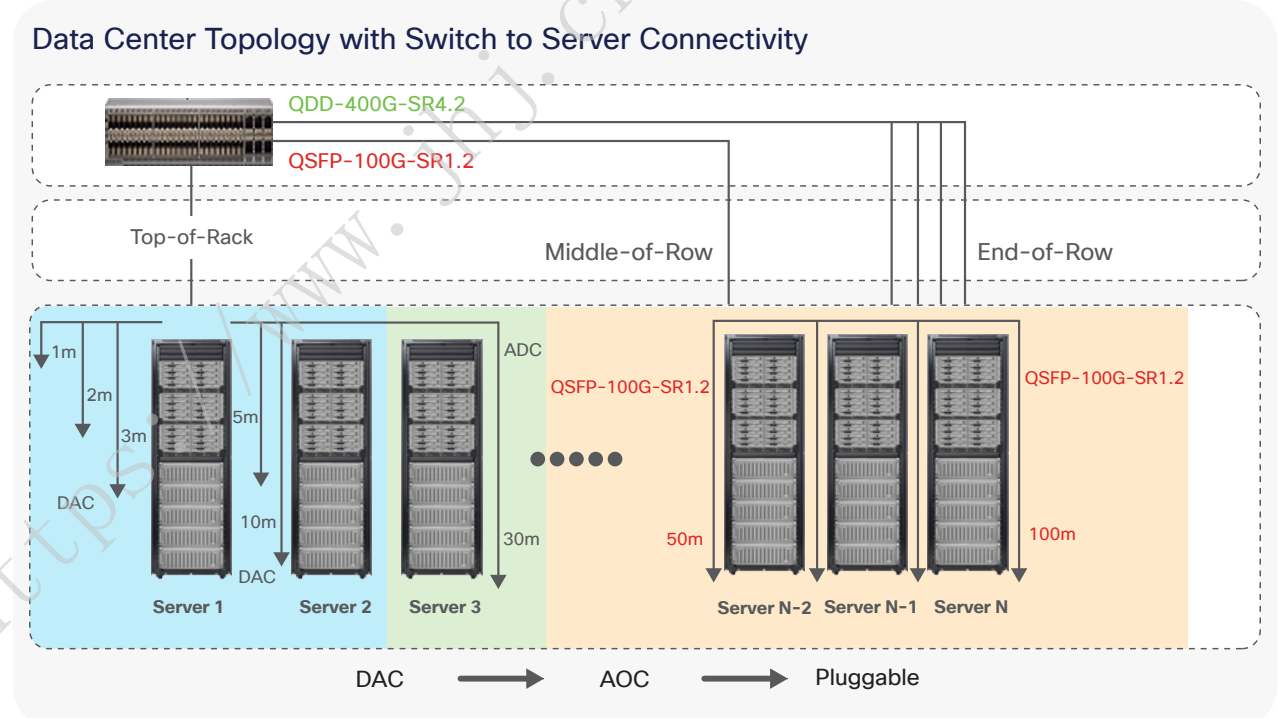

Much like the Cisco 40Gb BiDi and the Cisco 40/100Gbps BiDi transceiver, the Cisco QSFP-100G-SR1.2 BiDi allows data center operators to reuse their existing duplex LC-connectorized MMF infrastructure as they upgrade from 10G SR or 40Gb BiDi to 100G SR1.2 BiDi. By upgrading network equipment one end at a time, operators can exercise flexibility in schedules and budgets.